

FREEWAY TURNSTILE

SPEEDBLADE

Speedblade is a type of motorized turnstile featured with sliding flaps operation principle. Housing materials and light weight cabinets' shape make Speedblade turnstile universal for large variety of facilities with heightened requirements to esthetic equipment appearance. As well as other turnstiles of freeway series, Speedblade has implemented anti-tailgating function. Sliding flaps are made of glass, polycarbonate is optional. Turnstiles can be controlled by push button or via ACS (access control system).



MOTORIZED TURNSTILE FEATURED

WITH SLIDING FLAPS OPERATION PRINCIPLE

 **500/900**
mm
PASSAGE WIDTH

 **30**
pers/min
CROSSING CAPACITY

 **0,8**
sec
OPENING/CLOSING

 **IP 41**
PROTECTIVE LEVEL

 **PASSAGE FOR DISABLED**

 **ANTI-TAILGATING**

 **BI-DIRECTIONAL**

Advantages

- Speedblade equipped with sensors that allows to detect tailgating
- Ultra quiet direct drive unit
- Successful combination of affordable price and high quality
- Customized surface finish and top lid
- Steadfast housing suitable for high traffic areas
- Solution for disabled and trolley access
- Can be integrated with any type of access control systems
- Low power consumption
- Low noise system operation
- Can be mounted on a mobile platform (CartPoland Frame-M)

Standard

- Wired remote control panel

Options

- Any access control systems upon request (e.g. passes counter, RFID device, coin acceptor push button, fingerprint, bar-code and QR-code reader etc.)
- Radio controller
- Heating function for external installation
- Automatic opening when power goes off

Technical Specifications:

Width, mm	Single pass (500) - 1080 Two pass (500+500) - 1870
Length, mm	1000
Height, mm	1000
Weight, kg (not more)	Single pass - 202 Two pass - 324
Mechanism	Motorized

Controlled by:



access control system;



manual control

When power goes OFF both directions are free.

Electrical Specifications:

- Voltage:
 - from the AC (100-240)V, 50/60Hz;
 - from a DC source 12 V;
- Maximum power consumption 155W per pass.

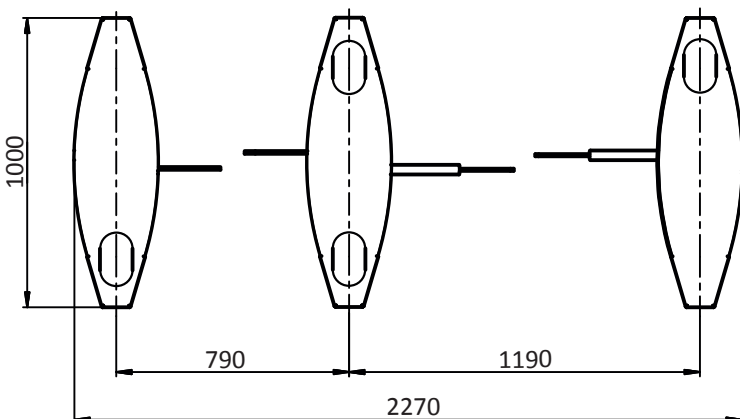
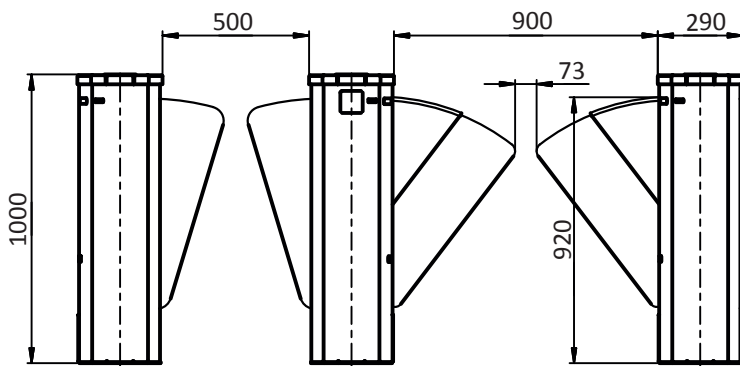

Materials*

Standard housing	Brushed SS AISI 304
Available housing	Brushed SS AISI 316 Polished SS AISI 304 Polished SS AISI 316 Powder coated RAL
Top lid	Black glass

Installation areas:

- Governmental Institutions
- Military Bases
- Nuclear Power Plants
- Production sites (Industrial Plants)
- Commercial areas
- Financial institutions
- Airport Premises
- Business (Office) Centers
- Hotels
- Sport Complexes
- Recreation areas
- Urban areas
- Education Institutions
- others

*other materials and colors available optionally up on request



CartPoland, Maciej Twardowski
Wólka Mińska ul. Olszowa 5,
05 - 300 Mińsk Mazowiecki

maciej@cartpoland.pl, Tel.: +48 606 773 276
inka@cartpoland.pl, Tel.: +48 795 15 83 20
www.cartpoland.pl | bramkiobrotowe.eu

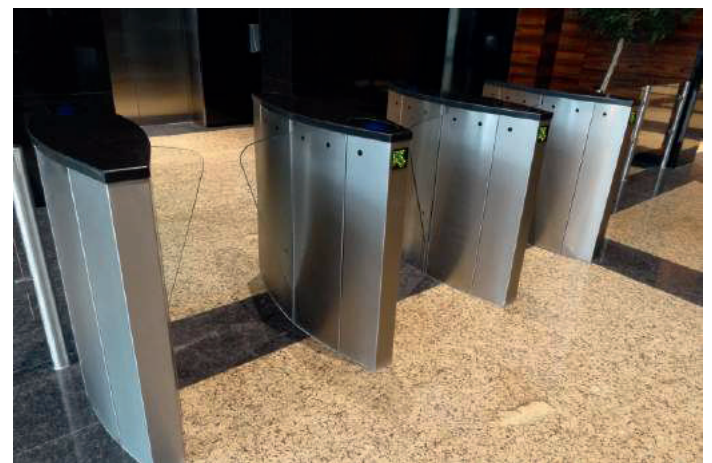
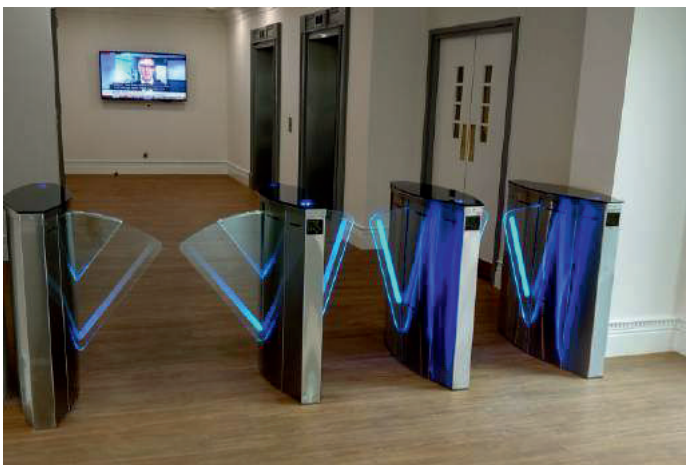

CartPoland, Maciej Twardowski
Wólka Mińska ul. Olszowa 5,
05 - 300 Mińsk Mazowiecki

maciej@cartpoland.pl, Tel.: +48 606 773 276
inka@cartpoland.pl, Tel.: +48 795 15 83 20
www.cartpoland.pl | bramkiobrotowe.eu

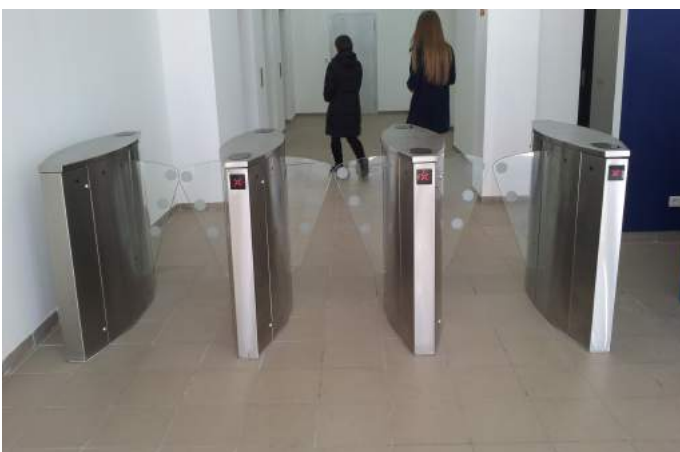

CartPoland, Maciej Twardowski
Wólka Mińska ul. Olszowa 5,
05 - 300 Mińsk Mazowiecki

maciej@cartpoland.pl, Tel.: +48 606 773 276
inka@cartpoland.pl, Tel.: +48 795 15 83 20
www.cartpoland.pl | bramkiobrotowe.eu